

*Summit Door, Inc.*

**Client:** Specification / Details

**Job name:** 20 Minute Rating

**P.O.#:** Positive Pressure

**Drawing by:** J B

**Date:** 12/19/02

**Scale:** 1:2

**Drawing #:**

**Drawing:** 1 of 3

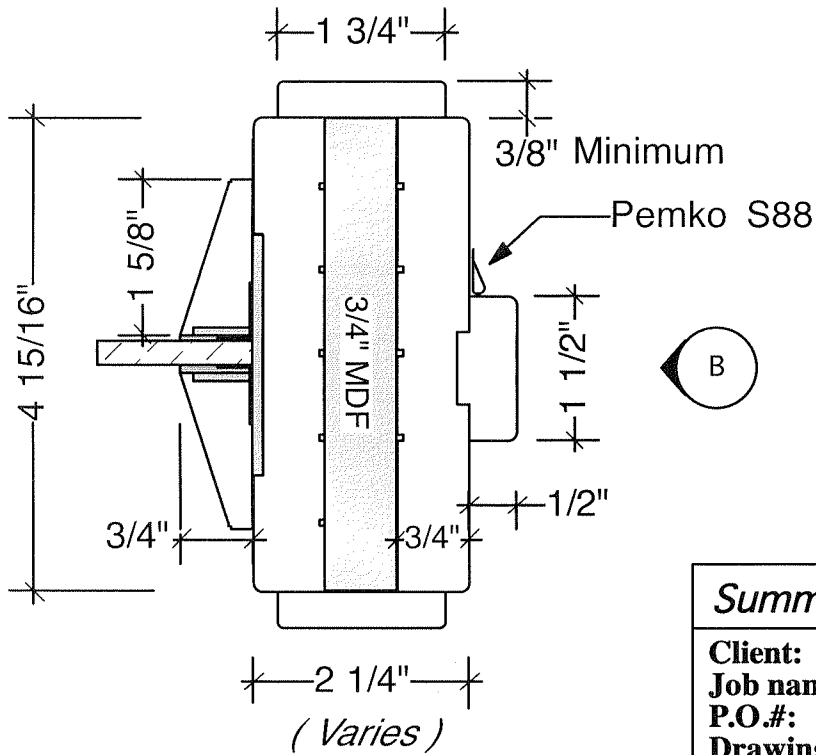
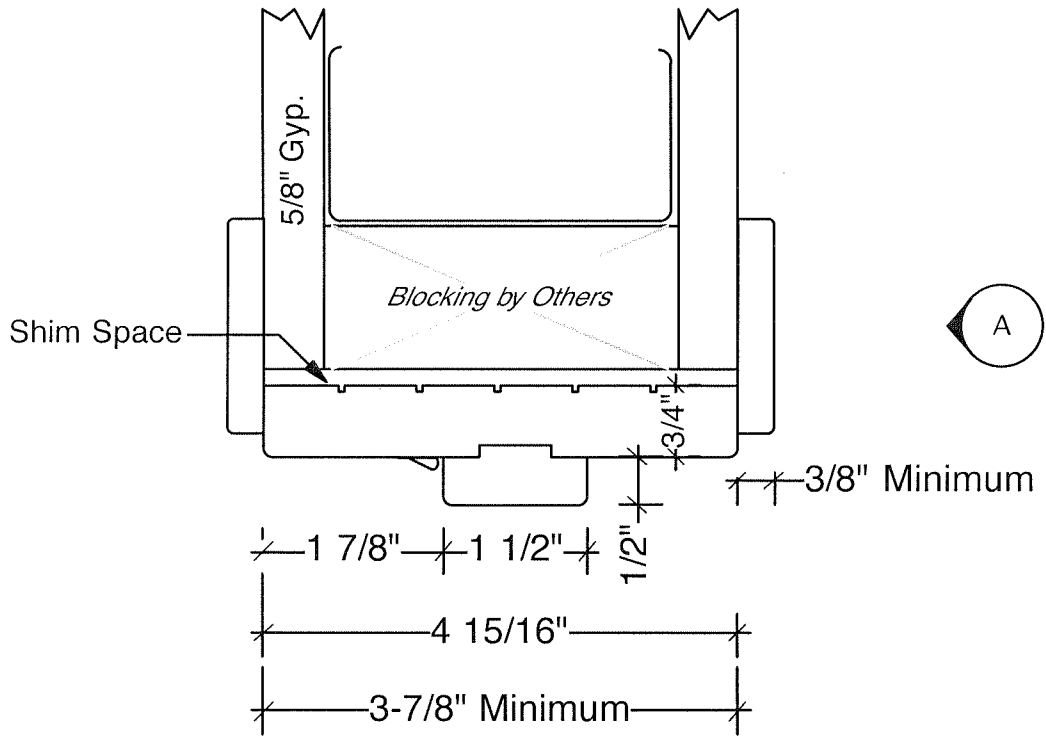

|                          |                                |
|--------------------------|--------------------------------|
| <i>Summit Door, Inc.</i> |                                |
| <b>Client:</b>           | <b>Specification / Details</b> |
| <b>Job name:</b>         | <b>20 Minute Rating</b>        |
| <b>P.O.#:</b>            | <b>Positive Pressure</b>       |
| <b>Drawing by:</b>       | <b>JB</b>                      |
| <b>Date:</b>             | <b>12/19/02</b>                |
| <b>Scale:</b>            | <b>1:2</b>                     |
| <b>Drawing #:</b>        |                                |
| <b>Drawing:</b>          | <b>2 of 3</b>                  |

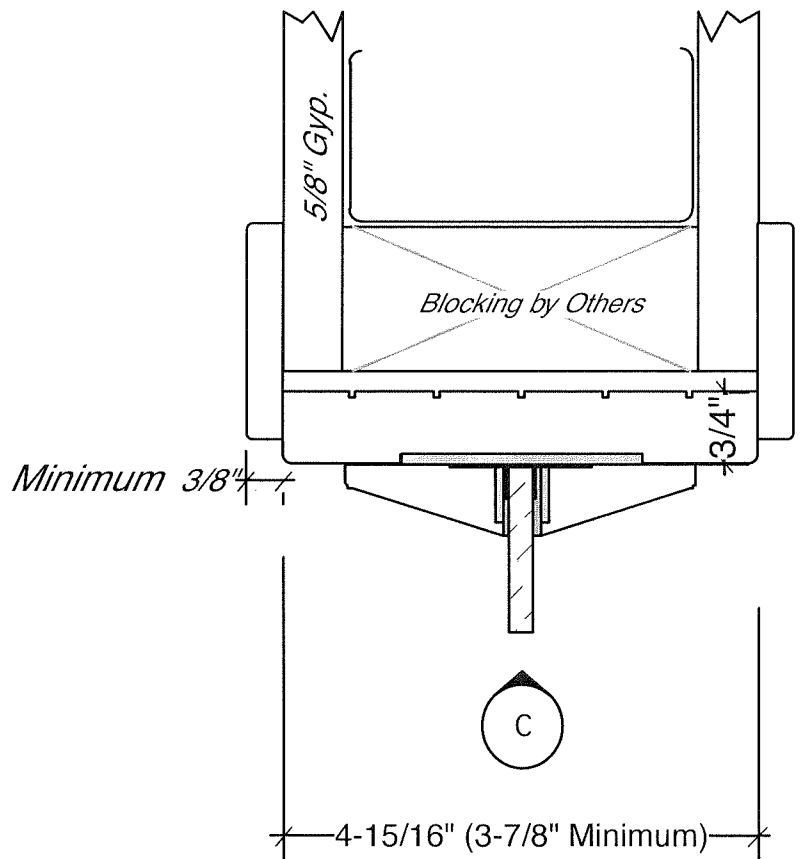
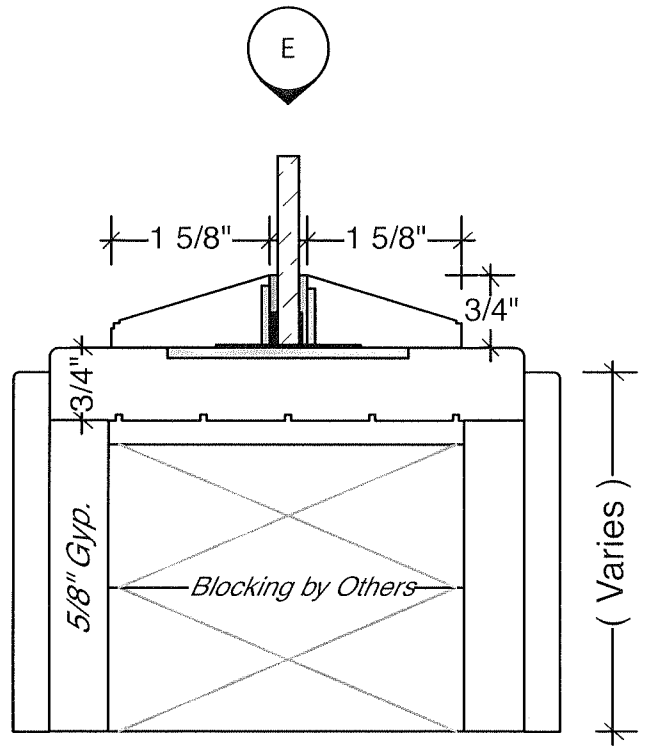
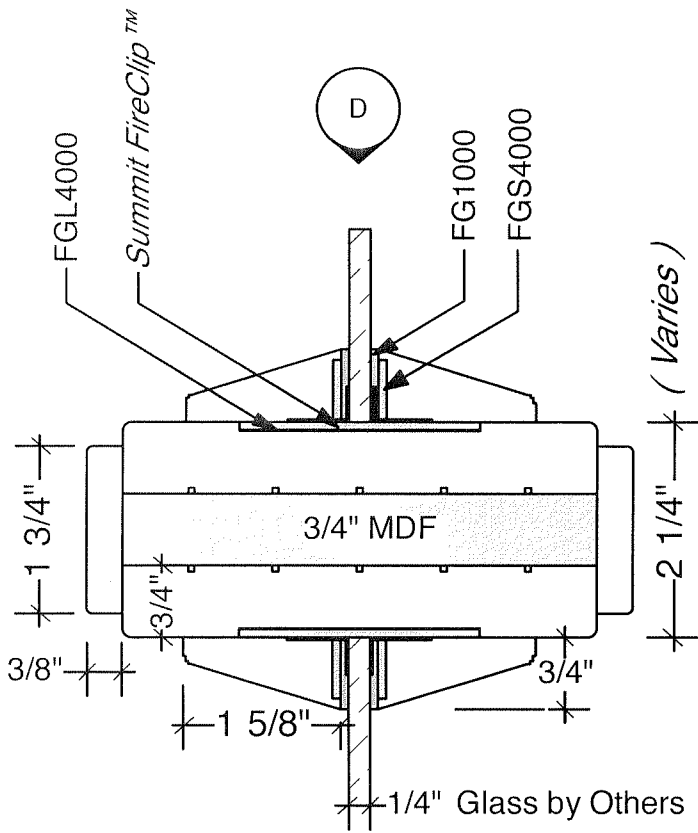

|                          |                         |
|--------------------------|-------------------------|
| <b>Summit Door, Inc.</b> |                         |
| Client:                  | Specification / Details |
| Job name:                | 20 Minute Rating        |
| P.O.#:                   | Positive Pressure       |
| Drawing by:              | J B                     |
| Date:                    | 12/19/02                |
| Scale:                   | 1:2                     |
| Drawing #:               |                         |
| Drawing:                 | 3 of 3                  |